

**SEETAL** SPRAY BOOTH P/L. ABN NO 53 005 268 600

56 JERSEY ROAD, BAYSWATER, VICTORIA, 3153.

TELEPHONE: (03) 9729-8733 FACSIMILE: (03) 9720-5684

**DESCRIPTION OF THE**

**SEETAL EUROCABIN SPACE SAVER**

**COMBINATION SPRAY BOOTH AND LOW BAKE OVEN**

The SEETAL SPACE SAVER is a fully down draught pressurized car Spray Booth Oven with:

- (a) Heated temperature controlled fresh air during the spray painting cycle, and
- (b) Direct fired heated air during the bake cycle.

The standard model is provided with concertina vehicle access doors, incorporating a personal access door built into one wing of concertina door arrangement and four laminated viewing windows. Extra escape door with viewing window is provided and fitted at suitable location.

The SEETAL SPACE SAVER is designed to be constructed on a fully inground water wash water curtain floor or on a dry exhaust filter system.

Assembled to a factory tested unit for easy assembly or relocation if necessary.

Seetal Space Saver Spray Booth Ovens are manufactured to comply with all relevant regulations, local and national.

Electrical: AS 3000 & AS 1825.  
Gas Code: AG 501 - 601.  
Latest addition of: AS NZ 4114.

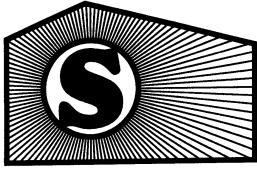

**SEETAL** SPRAY BOOTH P/L. ABN NO 53 005 268 600  
56 JERSEY ROAD, BAYSWATER, VICTORIA, 3153.  
TELEPHONE: (03) 9729-8733 FACSIMILE: (03) 9720-5684

- 2 -

In the "spray" position, the fresh air is brought in from the outside through a duct system into the heat chamber, for warming up (if necessary) to approx. 22<sup>0</sup>C - 25<sup>0</sup>C. It will then be delivered via a centrifugal fan, to a plenum chamber over the top of the booth section. From there the supply air is passed down through a set of filters in the ceiling to the working area (down draught system).

The air passes the operator vertically and leaves the spray booth through an opening under the vehicle being spray painted.

Exhaust filter system will clear the passing air from airborne paint particles.

The "non-sparking" tube axial fan pushes the cleaned air through the duct system out into the open outside of the building.

The booth airflow and heating in spray or bake is a patent once through system and is suitable for all types of automotive painting including Water Based Undercoats and Paints.

After the completion of the spray painting job, the operator sets the baking temperature and time then presses the "bake" button.

The control system of the spray booth will now automatically change the air flow to bake mode and the direct fired high low modulating unit will take air up to the required temperature (Max. 80<sup>0</sup>C) within approximately 1½ minutes.

After the preset time for baking has elapsed, automatically the air flow is once again switched the same way as in "spray" position and with the heater switched off, the whole plant is cooled down to a set cooling temperature.

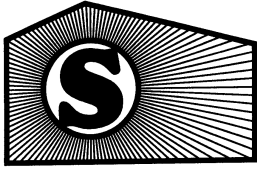

**SEETAL** SPRAY BOOTH P/L. ABN NO 53 005 268 600  
56 JERSEY ROAD, BAYSWATER, VICTORIA, 3153.  
TELEPHONE: (03) 9729-8733 FACSIMILE: (03) 9720-5684

- 3 -

SEETAL EUROCABIN SPACE SAVER

<u>DIMENSION</u>		
	Overall Height above ground model:	4600mm
	Overall Height In ground model:	4300mm
	Overall Length:	7300mm
	Overall Width:	4200mm
	Internal Height:	2600mm
	Internal Width:	4100mm
	Internal Length:	7200mm (Approx.)
	Door Width:	3000mm
	Door Height:	2220 / 2520 mm

INGROUND PIT DIMENSIONS:

Width:	4000mm
Length:	7000mm
Depth:	500mm

POWER REQUIREMENTS:

3 phase 32 amp per phase.  
1 neutral.

INLET FAN:

One (1) only Inlet Air Handling Unit with 7.5 Hp 940 Rpm 50 Hz Electric Motor, Direct Driven, Centrifugal Backward Curved Aluminium Air foiled Fan.  
MODEL: Seetal MMI 1000 and all ductwork, transitions and weather hoods.

EXHAUST FAN:

One (1) only Exhaust Tube Axial Air Handling Units with 4 Hp 1440 Rpm 50 Hz Electric Motors in Direct Driven Tube Axial Non Sparking Fan.  
MODEL: Seetal MME 1000 and all ductwork, transitions and weather hoods.

HEATING SYSTEM:

Approved direct fired gas L.P. or Natural with flame detection and supervision, as per Standard AG 501, fired with Seetal DF 850 MJ burner. Firing rate at 450 MJ per hour.

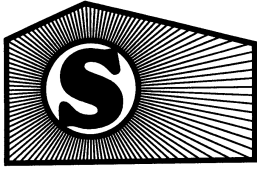

**SEETAL** SPRAY BOOTH P/L. ABN NO 53 005 268 600  
56 JERSEY ROAD, BAYSWATER, VICTORIA, 3153.  
TELEPHONE: (03) 9729-8733 FACSIMILE: (03) 9720-5684

- 4 -

TEMPERATURE:

During spray painting - adjustable to 20<sup>0</sup>C - 25<sup>0</sup>C + or - 2<sup>0</sup>C.  
During baking - adjustable to 35<sup>0</sup>C - 80<sup>0</sup>C + or - 2<sup>0</sup>C.

BAKING TIME:

Adjustable from 6 minutes to 60 hours.

AIR FOR SPRAY GUN:

Only available if the inlet fan and exhaust fan are working and all doors are shut, interlocked by solenoid valve.

ELECTRICAL CONTROLS:

Control of all functions is affected from a Master control panel.

It includes the following:

- (a) Main switch for power.
- (b) Light switch.
- (c) Timer circuit for baking time.
- (d) Hour meter.
- (e) Stop button.
- (f) Button to select "spray" or "bake" cycles.
- (g) Temperature setting controls over spray and baking.
- (h) Temperature gauge with digital readout.
- (i) Burner control and fault lights.
- (j) Fan motor protection.
- (k) Fault detection and trouble shooting lights.

ILLUMINATION:

Sixteen (16) pressurized twin fluorescent ceiling height light fittings, arranged in two rows of four each side, and two rows of two at each end and four vertical corner lights by four tubes, covered with 6mm framed laminated glass panel.

Above light system is a certified type. Certification No: EX 1392 (Refer to supplied copy of Certificate of Conformity).

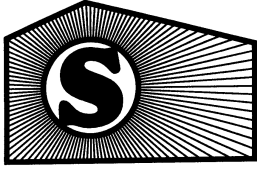

# SEETAL SPRAY BOOTH P/L. ABN NO 53 005 268 600

56 JERSEY ROAD, BAYSWATER, VICTORIA, 3153.  
TELEPHONE: (03) 9729-8733 FACSIMILE: (03) 9720-5684

- 5 -

## FRONT DOOR:

Front door construction is of concertina type, framed and sheeted with 0.9mm galvanized steel, hinged on full length piano hinges. Each wing will have center locking device to activate top and bottom pins built into door shell. Upper door track and weight carrier arranged with C section and ball bearing runners. 6mm laminated glass window in each of the four door wings will be provided, one door wing will have built in man service door.

## INLET FILTER:

Ten easily changed filter units in ceiling.  
Filter change takes only 30 minutes.  
Filter media Seetal A3 / 600 G Din 53438.

## EXHAUST AIR FILTER:

Easily replaceable dry filter located in floor.  
Full water washed floor water curtain exhaust filter.  
Includes supply of 3 x 2400 ducts, 1 x 1200 duct, 1 x exhaust weatherhood and 1 x inlet weatherhood.

## DUCTS:

All galvanized construction, includes bird screen and weather hood. Height to E.P.A. requirements.

## BOOTH FINISH (Inside and Outside):

1. Eurocabin Space Saver constructed in 50mm sandwich panels in white colourbond finish.
2. Remaining of Booth construction, doors, doorframe, light panels, plenum chamber etc. In galvanized metal each primed and finished in matching white enamel.

## MACHINE PLANT:

Full galvanized and painted blue.

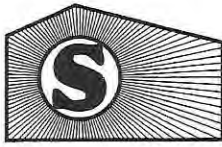

**SEETAL** SPRAY BOOTH P/L ABN 53 005 268 600  
56 JERSEY ROAD, BAYSWATER, VICTORIA 3153.  
TELEPHONE: (03) 9729 8733 FACSIMILE: (03) 9720 5684  
EMAIL: paul@seetal.com.au [www.seetal.com.au](http://www.seetal.com.au)

## SEETAL SPACE SAVER BOOTH

1. Light weight 'patented' machine construction is absolutely suitable for spray Booth roof mounted machines.
2. Equipped with extremely high performance aluminium, centrifugal, inlet fans. Static and dynamically balanced to exceed 960 rpm. Using less kw / hp per amount of air supply to booth (less carbon tax in the future).
3. Seetal uses tube axial type exhaust fans, that are much less likely to become critically unbalanced by paint build up than centrifugal fan wheels, therefore there is also less maintenance.

1	Air Exhaust Duct	7	Windows optional extra
2	Air Inlet Duct	8	Electric Control Panel
3	Burner Assembly	9	Escape Door with Step
4	Exhaust Manifold		
5	Pedestal Fan		
6	Door Frame Assembly		

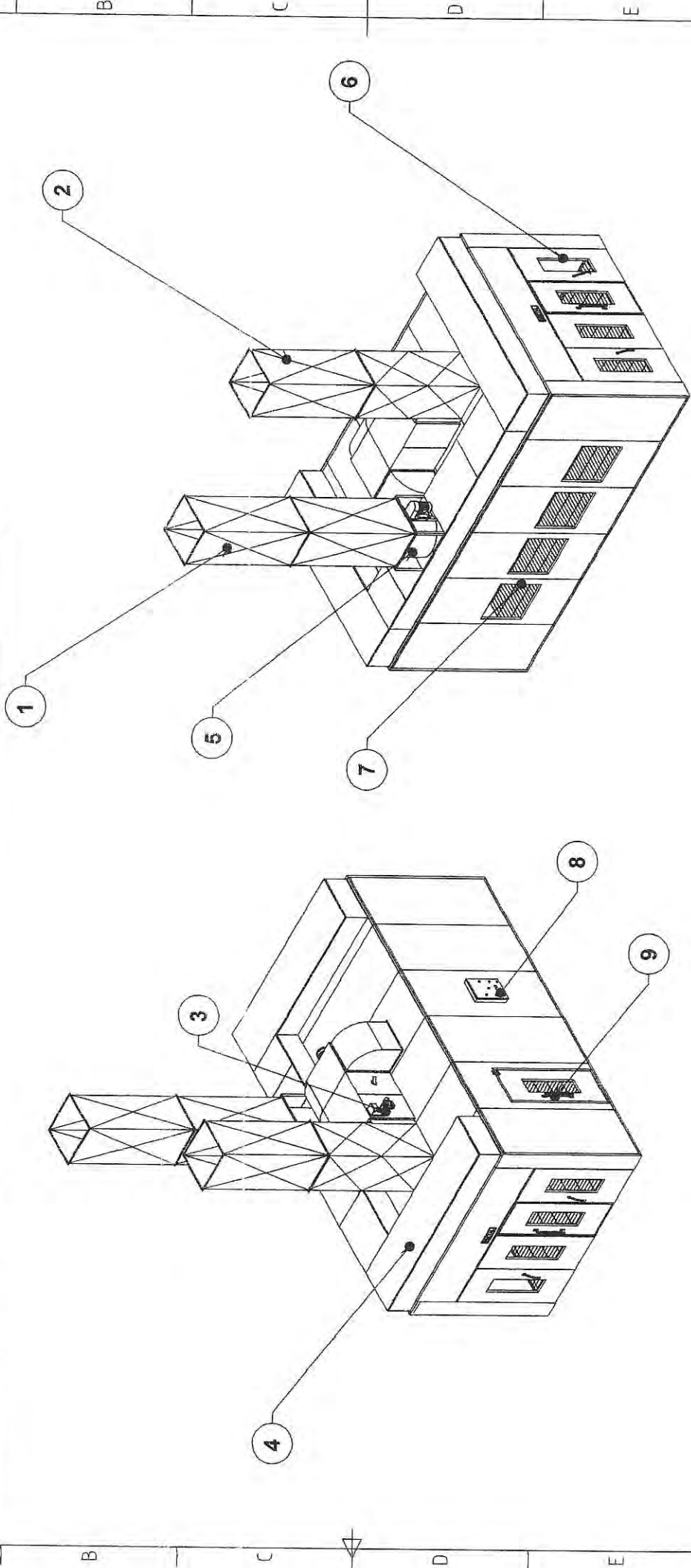

# MODEL: SPACESAVER (INGROUND)

Itemref	Quantity	Title/Name, designation, material, dimension etc	Article No./Reference
drawn by WE	des'n by PR	Checked by PR	Date 21/09/05
		Approved by - date PR - 00/00/00	Scale NTS
		Filename ACAD 083	Sheet 1/1
 <b>SEETAL</b> STANDARD INGROUND SPACESAVER SPRAY BOOTH PTY. LTD.			Edition 0 ACAD-083 7 8



**SEETAL** SPRAY BOOTH P/L ABN 53 005 268 600  
 56 JERSEY ROAD, BAYSWATER, VICTORIA 3153.  
 TELEPHONE: (03) 9729 8733 FACSIMILE: (03) 9720 5684  
 EMAIL: paul@seetal.com.au www.seetal.com.au

## MODEL: SPACESAVER (ABOVE GROUND)

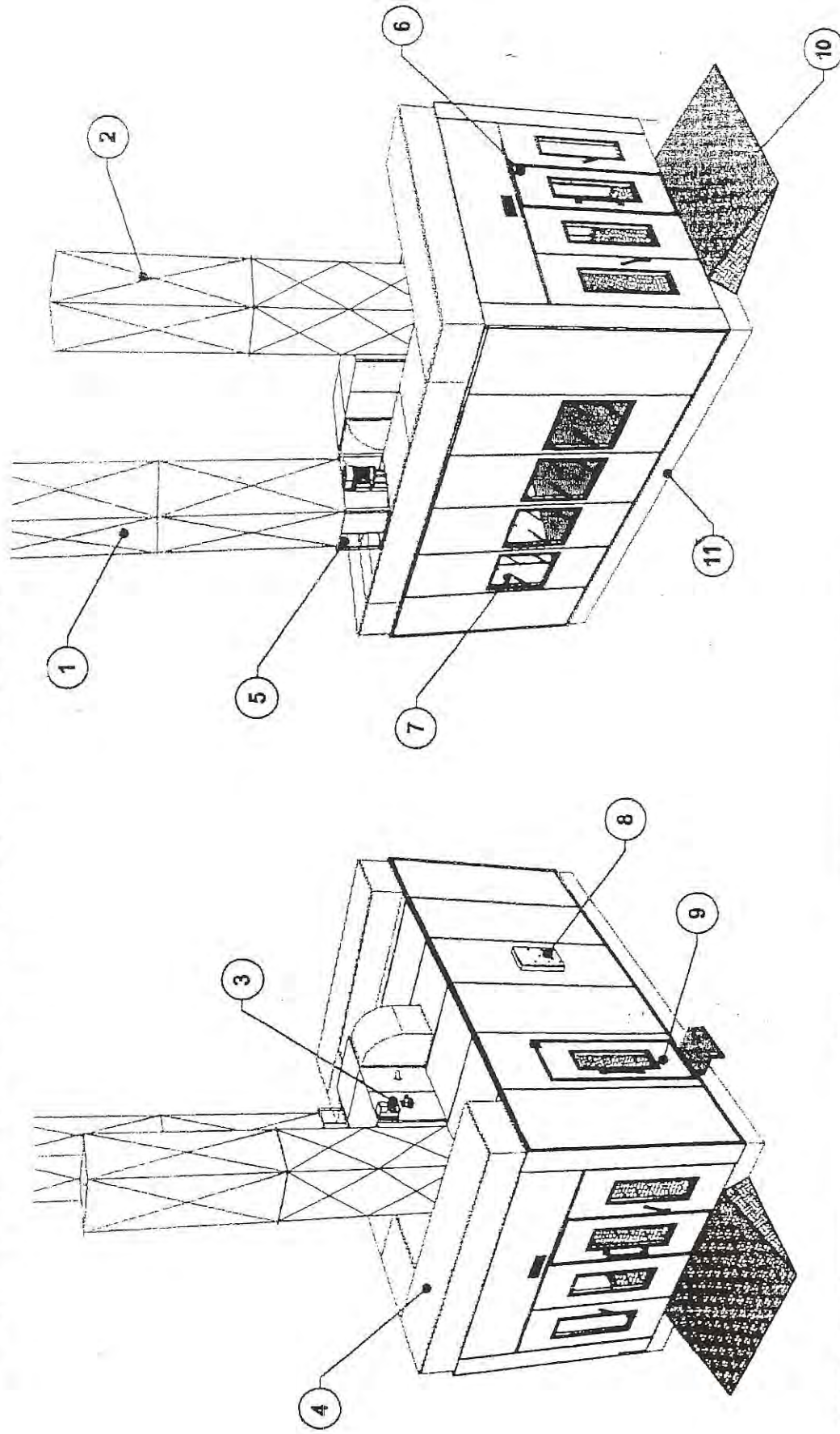

1	Air Exhaust Duct	7	Windows
2	Air Inlet Duct	8	Electric Control Panel
3	Burner Assembly	9	Escape Door with Step
4	Exhaust Manifold	10	Ramp
5	Pedestal Fan	11	Concrete Base
6	Door Frame Assembly		





**SEETAL** SPRAY BOOTH P/L ABN 53 005 268 600  
56 JERSEY ROAD, BAYSWATER, VICTORIA 3153.  
TELEPHONE: (03) 9729 8733 FACSIMILE: (03) 9720 5684  
EMAIL: paul@seetal.com.au [www.seetal.com.au](http://www.seetal.com.au)



**EUROCABIN SPACE SAVER**



**SEETAL** SPRAY BOOTH P/L ABN 53 005 268 600  
56 JERSEY ROAD, BAYSWATER, VICTORIA 3153.  
TELEPHONE: (03) 9729 8733 FACSIMILE: (03) 9720 5684  
EMAIL: paul@seetal.com.au [www.seetal.com.au](http://www.seetal.com.au)



**EUROCABIN SPACE SAVER**